



POM2 Universal Test System

PONOVO POWER CO., LTD.
www.ponovo.net





POM2 Universal Test System



POM2 universal test system is the best modular designed relay tester with local control system. There are 2 models, the POM2-6143 and POM2-3243. The POM2-6143 with 6×15A and 4×300V, the POM2-3243 with 3×20A and 4×300V.

POM2 universal test system could be used for testing all kinds of relays. Its local control system is with 10.4inch LCD screen based on Windows system.

POM2 universal test system support both local control and external PC control.

Product Features

- POM2-6143: 6×15A, 4×300V; POM2-3243: 3×20A, 4×300V
- Aux DC (0-300V), DC measuring inputs
- 8 binary inputs, 8 binary outputs
- Adjustable threshold (0-400V) or potential free for binary inputs
- Can support test the relay with GOOSE of IEC61850-8-1
- More than 500 relay templates offered freely to do automatic testings
- Support to import CSV, RIO and XRIO files

➤ Modular Structure

- ❖ Evolutional modular structure design with only 4 modules
- ❖ Disassembling and assembling work can be completed easily
- ❖ Easy local maintenance by our local agent or even by user himself

➤ Local Control

- ❖ Quick operation and convenient button control
- ❖ Built-in industrial mouse
- ❖ 10.4inch color LCD display
- ❖ 20 built-in test-ready modules capable for testing all type of relays
- ❖ More optional test modules can be added upon user request
- ❖ Report can be saved to flash drive through USB port

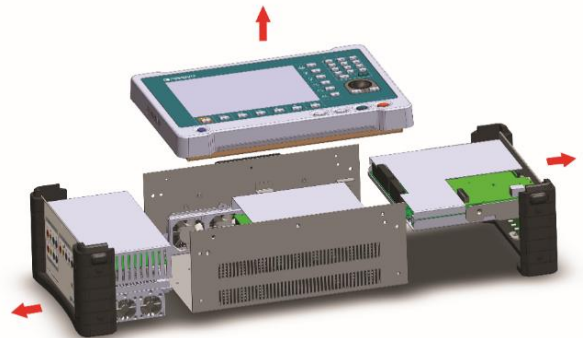

➤ External PC Control

- ❖ POM2 can also be controlled via PowerTest relay test software running on external PC



➤ Real-Time Outputs Display

- ❖ Real-time output waveform display helps the fast troubleshooting of wiring and test circuitry before test actual started.
- ❖ User can also use this provision to analyze the external signals, such as phase angle, power, harmonic, etc.

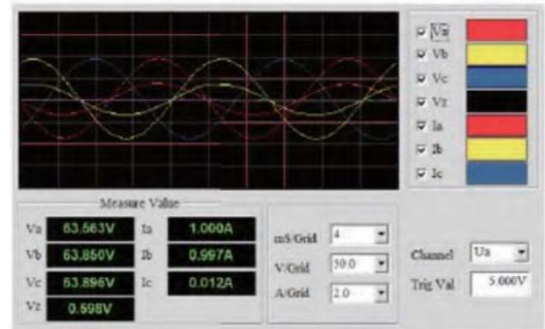

➤ IEC 61850 Function

- ❖ POM2 series provides analog voltage/current signal to relay and the GOOSE message from relay is received and analyzed by relay test set.



Application

▪ Relay test

- Distance protection
- Differential protection
- Directional relay
- Time-inversed current relay
- Auto-reclosing, etc.

▪ Measuring and control device

- Synchronizer
- Transducer
- Energy meter
- df/dt, etc.

▪ System simulation

- Transient, steady-state fault simulation
- Playback of COMTRADE format file

▪ Calibration

- 0.5 Class energy meter
- Disturbance recorder
- Indicating meters, etc.



POM2-6143 & POM2-3243 Panels

The front panel and right panel are same, the left panel is different.

▪ POM2-6143 & POM2-3242 Front Panel

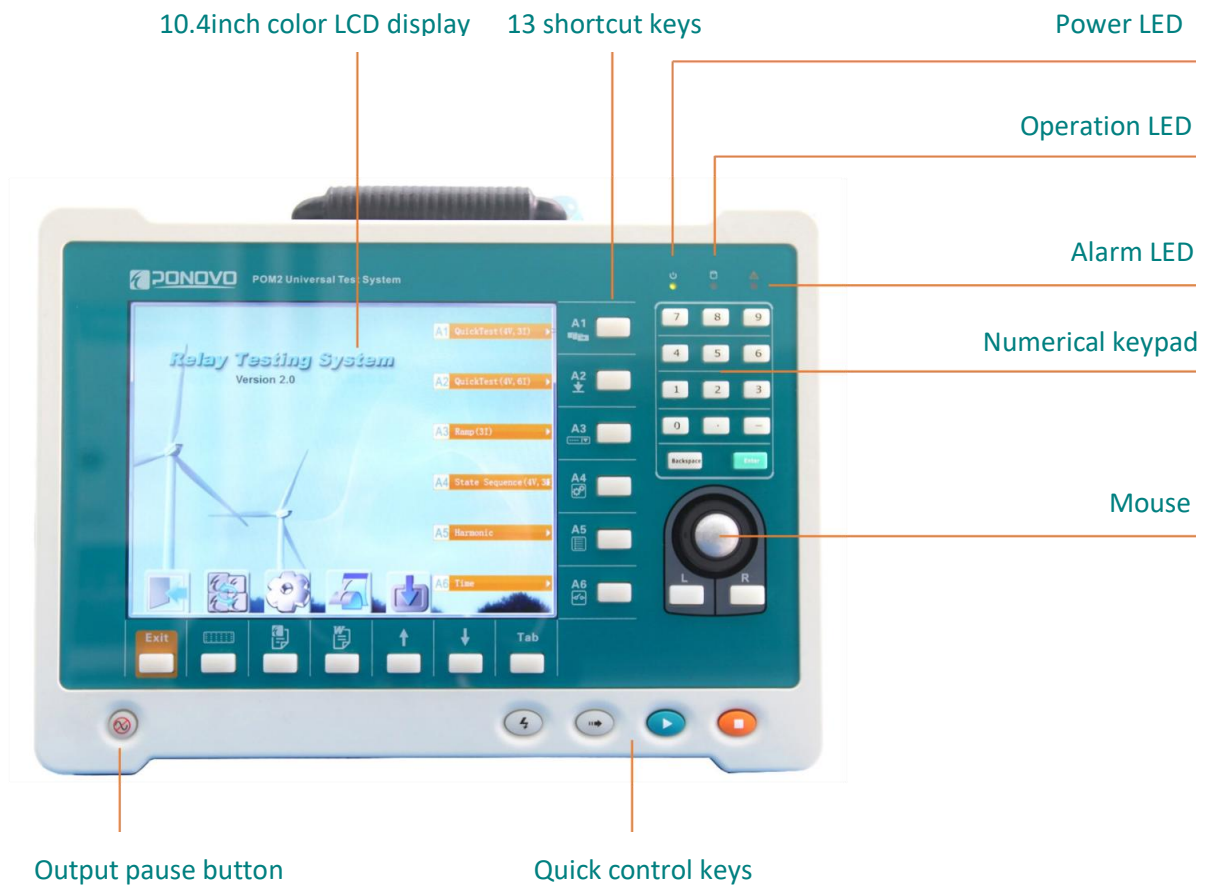

▪ POM2-6143 Left Panel

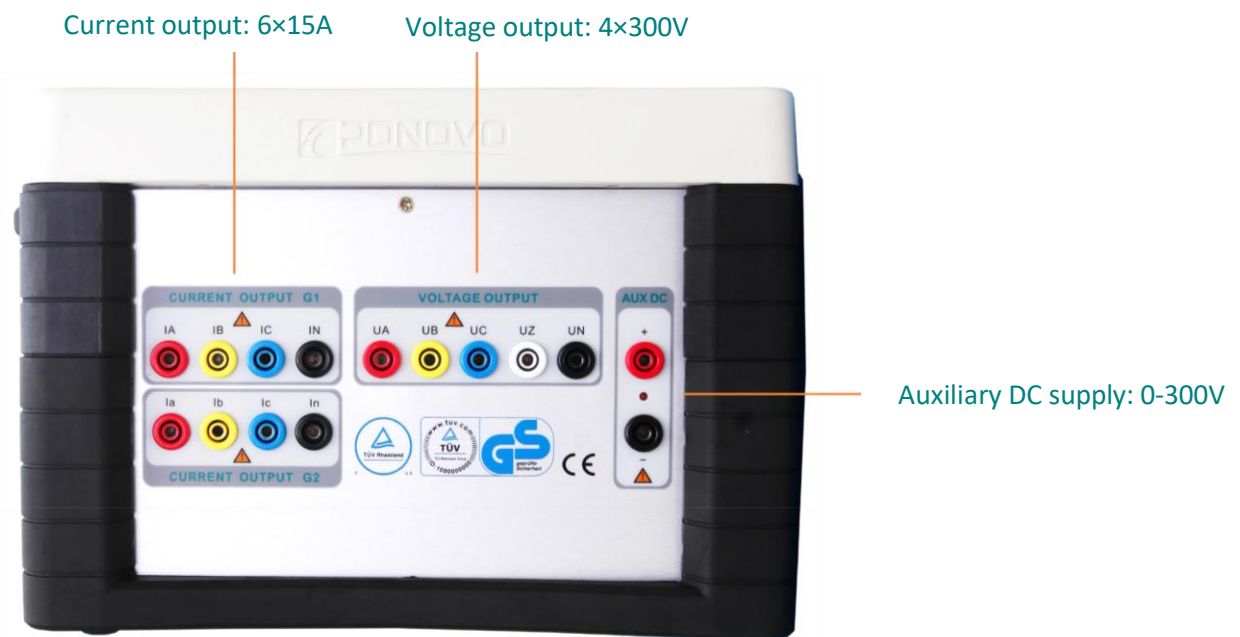

▪ POM2-3243 Left Panel

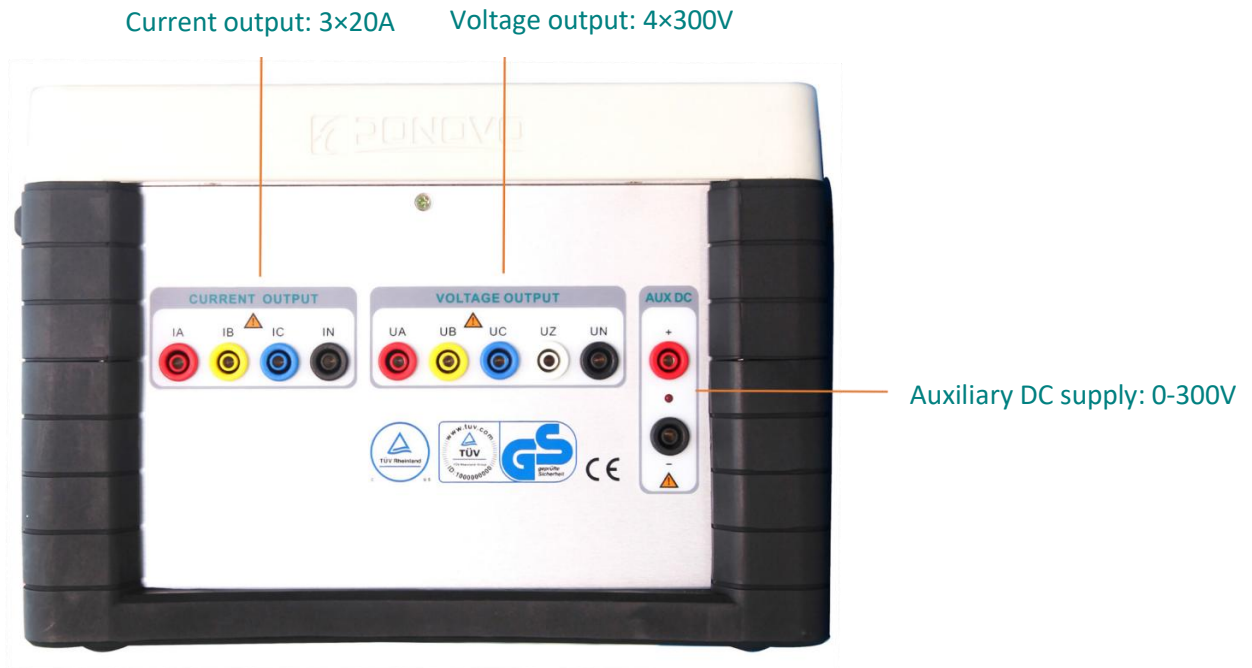

▪ POM2-6143 & POM2-3243 Right Panel

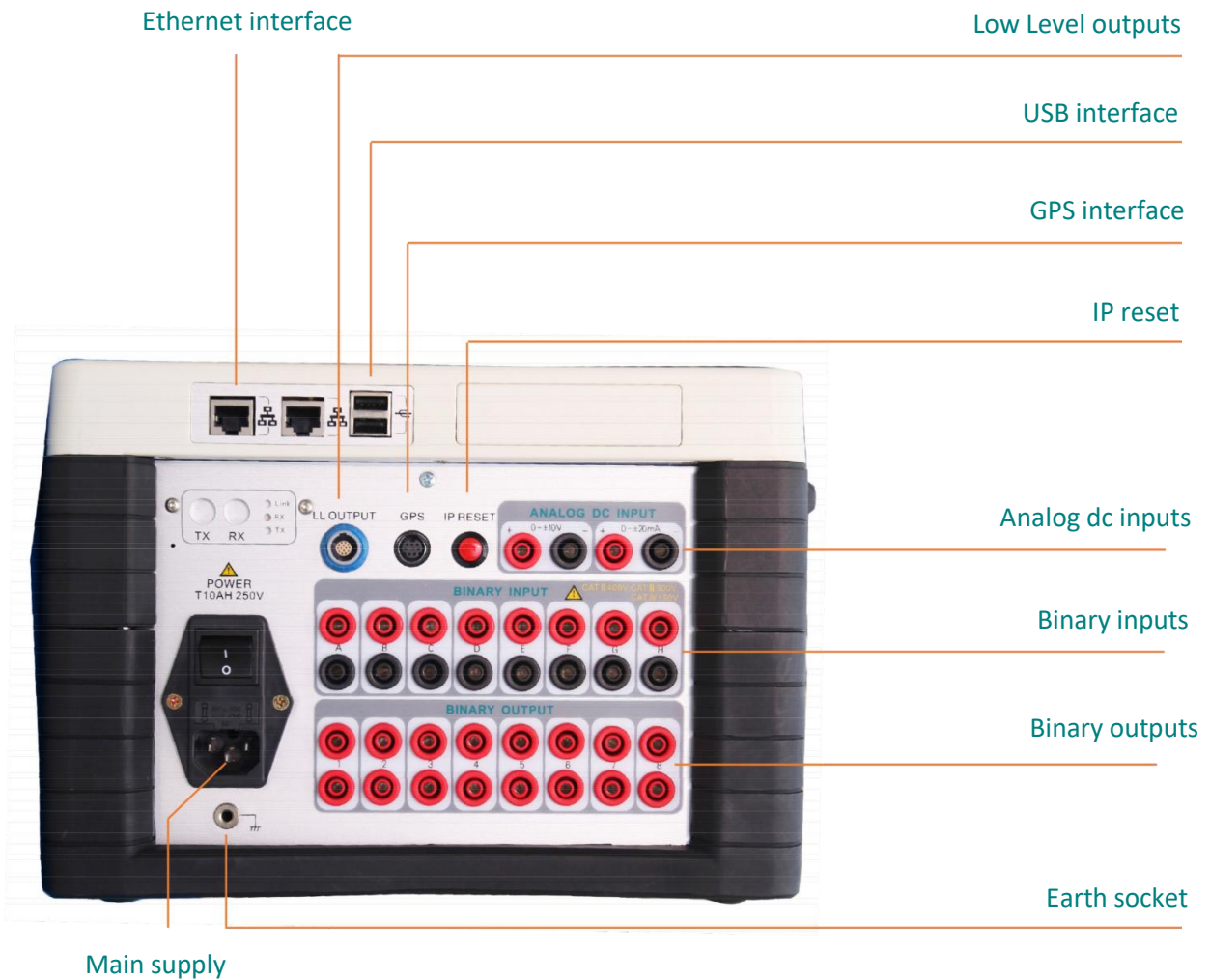

Test functions according to IEEE relay code

IEEE. NO.	DEVICE
2	Time Delay Starting or Closing Relay
21	Distance Relay
24	Volts per Hertz Relay
25	Synchronizing or Synchronism-Check Device
27/27N	Undervoltage Relay
30	Annunciator Relay
32	Directional Power Relay
36	Polarity or Polarizing Voltage Devices
37	Undercurrent or Underpower Relay
40	Field (over/under excitation) Relay
46	Reverse phase or Phase-Balance Current Relay
47	Phase-sequence or phase-balance voltage relay
50/50N	Instantaneous Overcurrent
51/51N	AC Time Overcurrent Relay
52	AC Circuit Breaker
53	Field Excitation Relay
55	Power Factor Relay
56	Field Application Relay
58	Rectification failure relay
59/59N	Overvoltage Relay
60	Voltage or Current Balance Relay

IEEE. NO.	DEVICE
61	Density switch or sensor
62	Time-Delay Stopping or Opening Relay
64	Ground Detector Relay
67/67N	AC Directional Overcurrent Relay
68	Blocking or "out of step" Relay
74	Alarm Relay
76	DC Overcurrent Relay
78	Phase-Angle Measuring Relay
79	AC-Reclosing Relay
81/81U/O/R	Frequency Relay
82	DC load-measuring reclosing relay
85	Carrier or pilot-receiver relay
86	Lock-out relay
87	Differential Protective Relay
91	Voltage Directional Relay
92	Voltage and Power Directional Relay
94	Trip Relay
Other Functions (Optional)	IEC61850, Lower level outputs, Transducer, Energy meter (The 4 functions can be realized when POM2 controlled by external PC, local control can't)

Local Control Test Modules for POM2 Series

Module	Description	POM2-6143	POM2-3243
QuickTest (4V,3I)	Manually or automatically control over 4 voltage and 3 current sources	√	√
QuickTest(4V,6I)	Manually or automatically control over 4 voltage and 6 current sources	√	-
Ramp	Realize the ramping for different quantities in 3 current mode	√	√
State Sequence(4V,3I)	Flexible edit of test sequences in 3 current and 4 voltage mode	√	√
State Sequence(4V,6I)	Flexible edit of test sequences in 6 current and 4 voltage mode	√	-
Directional	Check directional Relay	√	√
Time	Check the tripping time	√	√
Distance(R-X)	Check zone settings (R-X) of impedance relay	√	√
Distance(Z-Phi)	Check zone settings(Z-Phi) of impedance relay	√	√
Differential (3I)	Check IR/ID characteristic of different relay with 3 currents	√	√
Differential(6I)	Check IR/ID characteristic of different relay with 6 currents	√	-
Time Inversed Current	Check time inversed current relay based on IEC standard	√	√
Frequency Relay	Check under frequency relay	√	√
Harmonic	Edit harmonic components to the output	√	√
Auto-Reclosing	Check Auto-reclosing function	√	√
TransPlay(4V,3I)	Play back COMTRADE format file	√	√
U,I,T Relay (AC)	Check ac type auxiliary relay and time relay	√	√
U,I,T Relay (DC)	Check dc type auxiliary relay and time relay	√	√
Voltage Relay	Check voltage relay	√	√



PowerTest - Relay Test Set Software

For all the three phase or six phase relay testers of PONOVO, one universal software can be used, the name is **PowerTest** software. PowerTest is a relay test software that includes different test packages, the **Basic** package, **Protection** package, **Advanced** package, **Special** package, **New Modules**, which packages includes different testing module, that can be used for all kinds of relay testing, and it also has the special package for more testing application, such as energy meter, etc. Besides local control, POM2 can also be controlled via PowerTest relay test software running on external PC.

➤ Basic Package

In the **Basic** package, there are different Quick Test modules, Time module, State Sequence, Ramp, Harmonic, CB Operation, Non-electricity Check, and TransPlay for playing back the comtrade file.

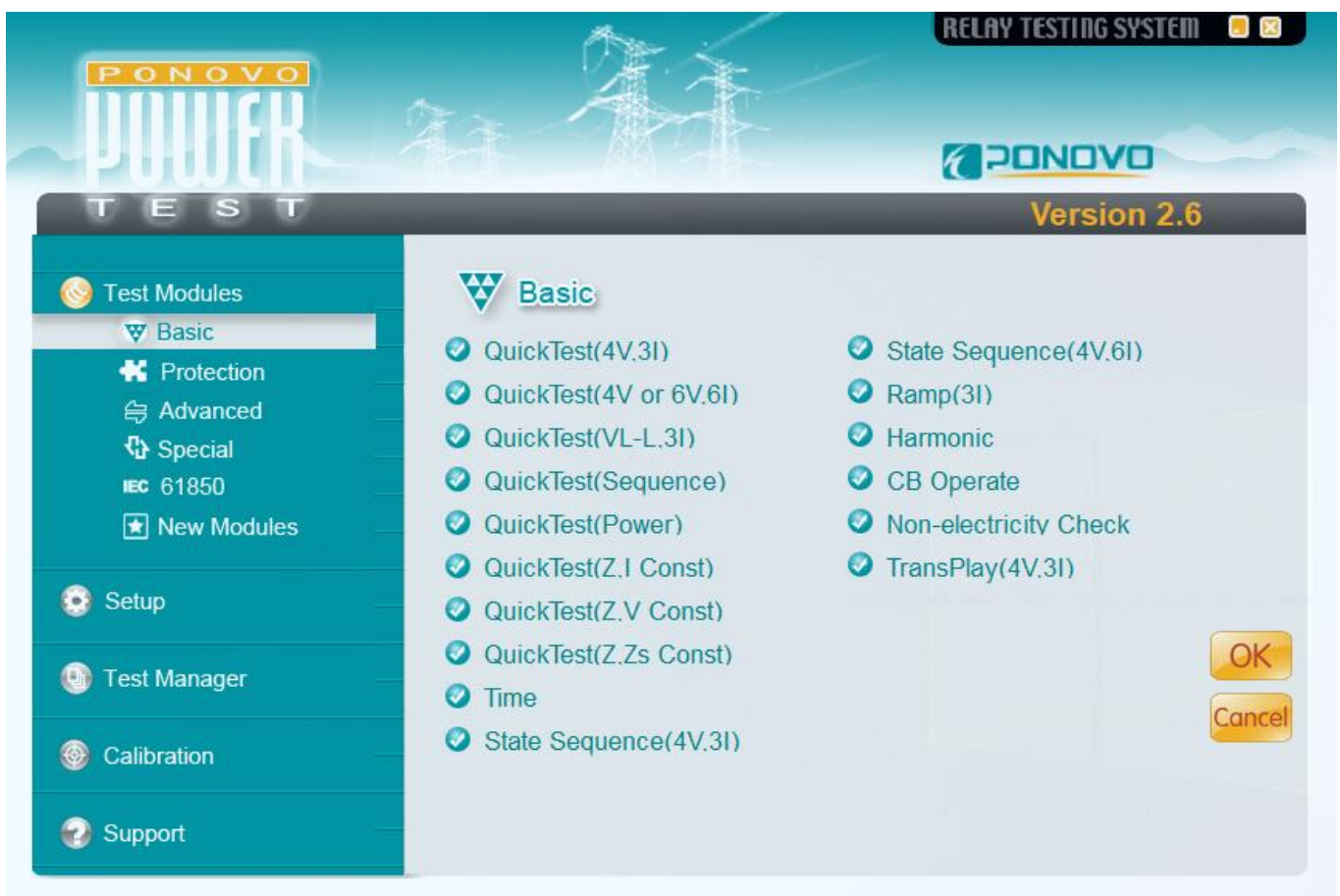

QuickTest (4V. 3I)

- ❖ 4 voltage and 3 current sources available for test relay
- ❖ Amplitude, phase angle and frequency of voltage and current sources can be controlled independently
- ❖ Test can be in manual or auto mode

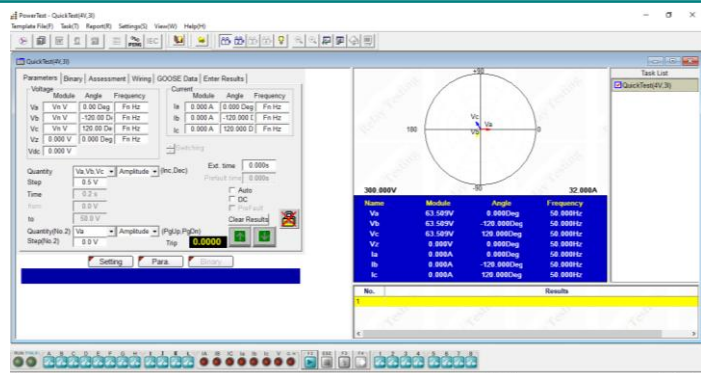

Name	Module	Amplitude	Frequency
Va	63.589V	0.000Deg	50.000Hz
Vb	63.500V	120.000Deg	50.000Hz
Vc	63.509V	179.000Deg	50.000Hz
Ia	0.000A	0.000Deg	50.000Hz
Ib	0.000A	-120.000Deg	50.000Hz
Ic	0.000A	120.000Deg	50.000Hz

QuickTest (4V,6I)

- ❖ 4 voltage and 6 current sources available for test relay
- ❖ Amplitude, phase angle and frequency of voltage and current sources can be controlled independently
- ❖ Test can be in manual or auto mode
- ❖ This module can be used by POM2-6143 only

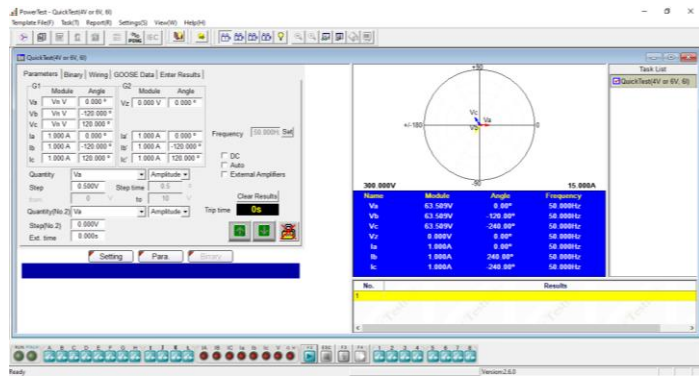

QuickTest (VL-L, 3I)

- ❖ Easy to control the phase-phase voltage, 3V0 (zero sequence voltage) and 3 currents
- ❖ Amplitude, phase angle and frequency of current sources and phase-phase voltage, zero sequence voltage can be controlled independently
- ❖ Test can be in manual or auto mode

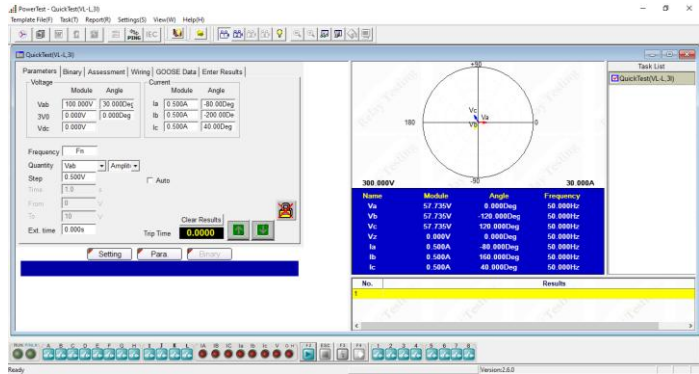

QuickTest (Sequence)

- ❖ Easy to control the sequence components (positive sequence, negative sequence and zero sequence) for voltage and current
- ❖ Amplitude and phase angle of the sequence components of voltage and current can be controlled independently
- ❖ Test can be in manual or auto mode

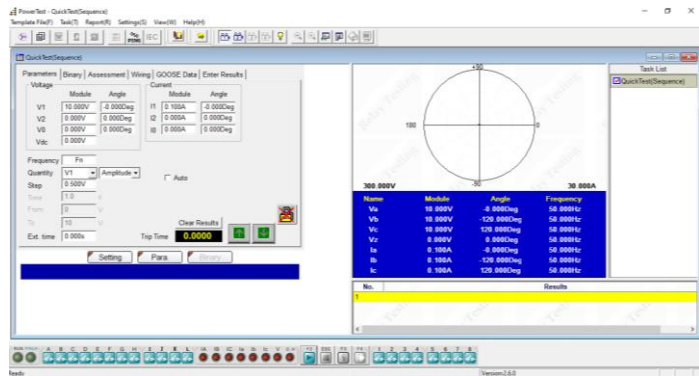

QuickTest (Power)

- ❖ Easy to control the output of power, including active power, reactive power and apparent power
- ❖ Amplitude of active power, reactive power and apparent power can be controlled independently
- ❖ Test can be in manual or auto mode

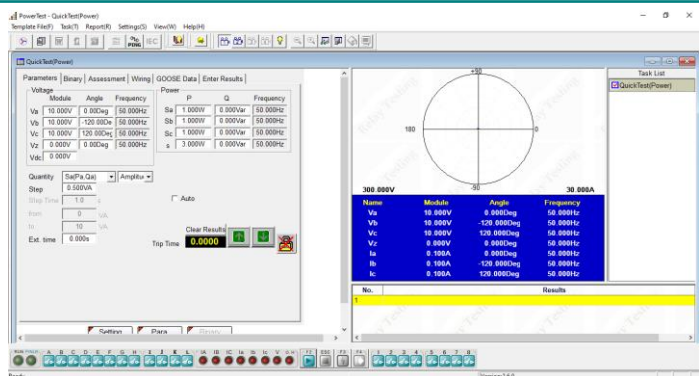

QuickTest (Z, I Const)

- ❖ Easy to test impedance relay with constant current
- ❖ Set the fault impedance and fault current, obtain the amplitude and phase angle of each phase voltage and current according to the fault type
- ❖ Can manually or automatic search the relay operation value

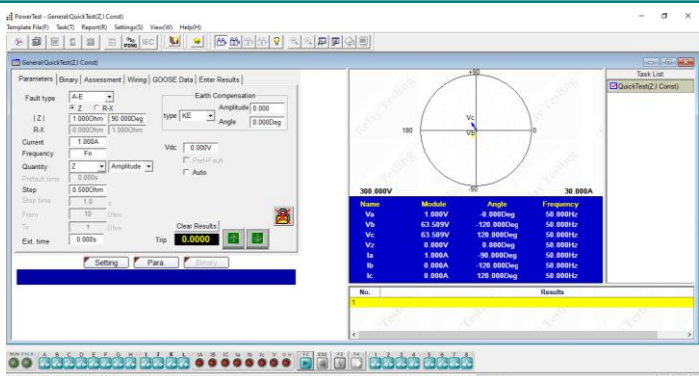

QuickTest (Z, V Const)

- ❖ Easy to test impedance relay with constant voltage
- ❖ Set the fault impedance and fault voltage, obtain the amplitude and phase angle of each phase voltage and current according to the fault type
- ❖ Can manually or automatic search the relay operation value

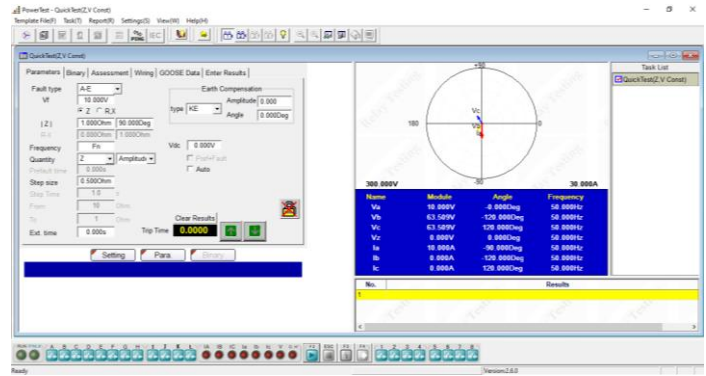

QuickTest (Z, Zs Const)

- ❖ Easy to test impedance relay with constant system impedance
- ❖ Set the fault impedance and system impedance, obtain the amplitude and phase angle of each phase voltage and current according to the fault type
- ❖ Can manually or automatic search the relay operation value

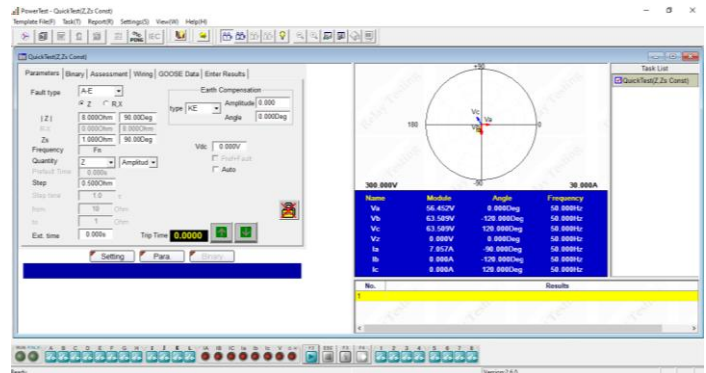

Time

- ❖ Time module is used to test trip delay time of protection relay
- ❖ Various value can be set separately, such as pick up value, delay time, pre-fault time, post-fault time, binary input/output, the voltage and current at pre-fault and fault state, characteristic definition, etc.

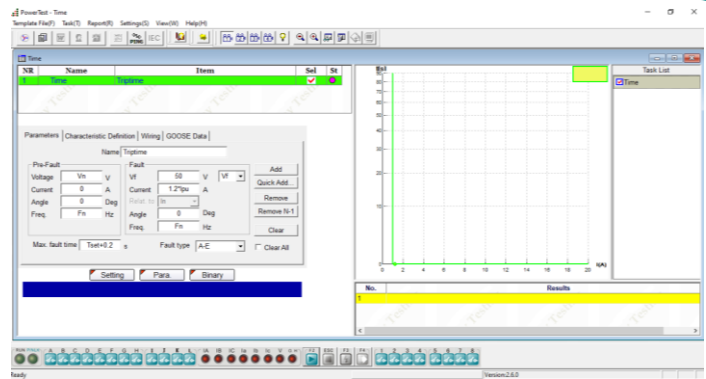

State Sequence (4V, 3I)

- ❖ Used to define multiple continuous state sequences for special test applications, such as generate a series of states to test the tripping time and close time
- ❖ 4 voltage and 3 current sources available for each state
- ❖ Trigger condition in each state can be set separately

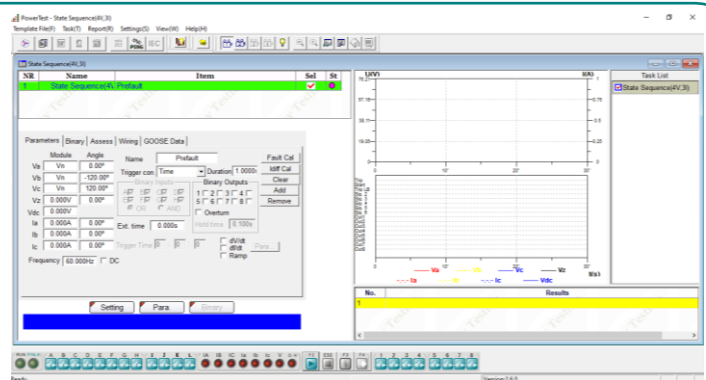

State Sequence (4V, 6I)

- ❖ Used to define multiple continuous state sequences for special test applications, such as generate a series of states to test the tripping time and close time
- ❖ 4 voltage and 6 current sources available for each state
- ❖ Trigger condition in each state can be set separately
- ❖ This module can be used by POM2-6143 only

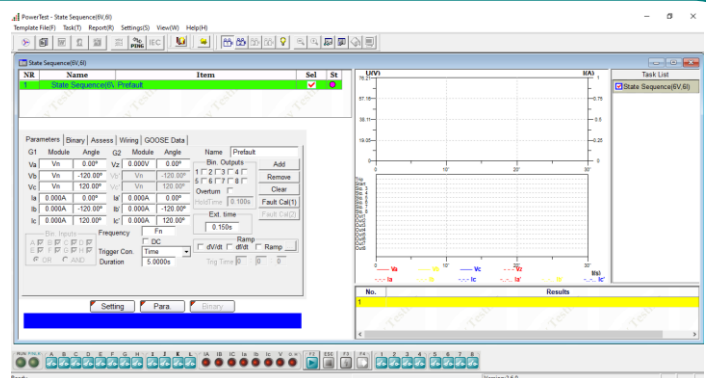

Ramp (3I)

- ❖ Specially designed to realize RAMP for different test applications, such as pick up/drop off value checking, directional relay testing, maximum torque angle checking etc.
- ❖ Both pulse ramp and linear ramp available
- ❖ Can search the relay operation value automatically

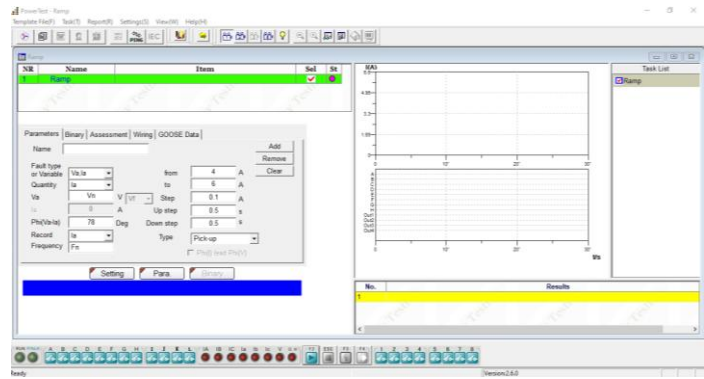
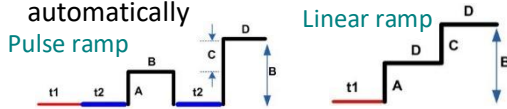

Harmonic

- ❖ Can generate harmonics for all voltage and current outputs
- ❖ Can check the 2nd / 3rd / 4th / 5th harmonic restraint of current differential
- ❖ Can check the harmonic measurement of the relay up to 31st harmonic
- ❖ Can set the harmonic for each channel separately

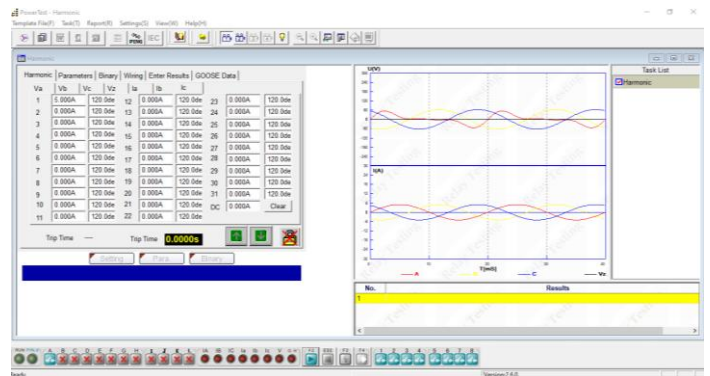

CB Operate

- ❖ Can check different types of line protection system, including over current, distance, etc.
- ❖ Can check the whole relay system, including auto-reclosing and circuit breaker simulate
- ❖ Can set different fault type
- ❖ Can do end-to-end test with GPS control mode

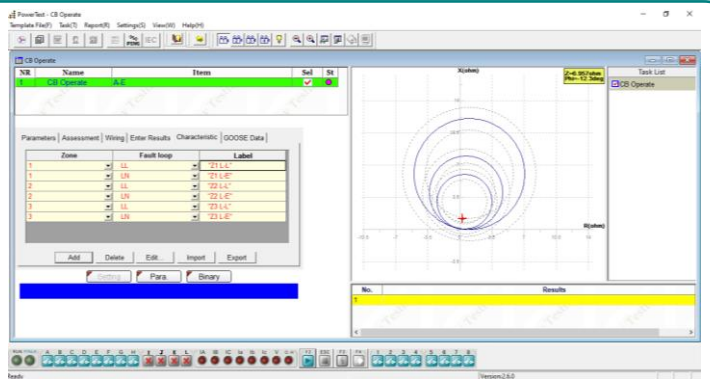

Non-electricity

- ❖ Give tips before and after testings to have test scheme prepared well and finished well
- ❖ Neither has any output value nor judge the binary input. It only generates a complete report for project check from appearance and safety.

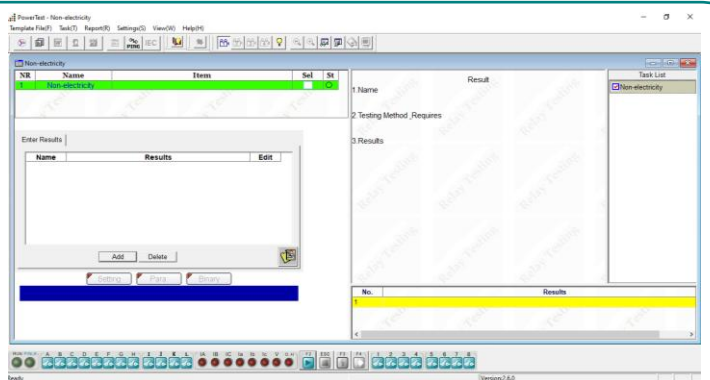

Transient Playback (4V,3I)

- ❖ Can play back the COMTRADE format file which records 4 voltage channels and 3 current channels
- ❖ Display the waveform and data of the imported COMTRADE file

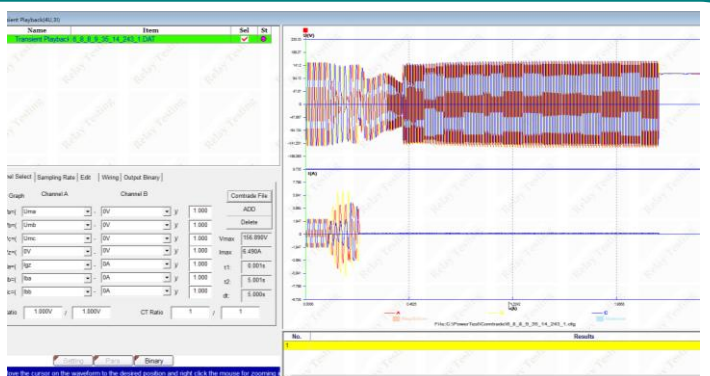

➤ Protection Package

In protection package, there are more testing modules for relay's characteristics testings, such as Distance, Differential, Directional, Time Inversed Current, Time Inversed Voltage, Frequency, Auto-Reclosing etc.



Distance (R-X)

- ❖ Can test impedance relay with R-X setting in different ways
- ❖ Input impedance characteristic to Z plain
- ❖ Associate the characteristic with relay settings
- ❖ Select test point/ items directly on Z plain or in setting box
- ❖ Zone verification
- ❖ Z-T test
- ❖ Edit new characteristic

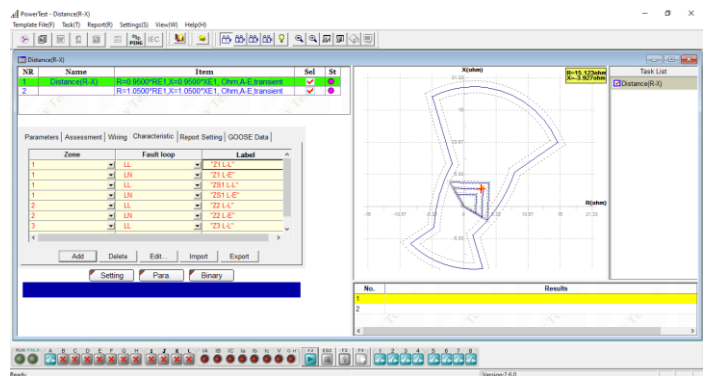

Distance (Z-Phi)

- ❖ Can test impedance relay with Z-Phi setting in different ways
- ❖ Input impedance characteristic to Z plain
- ❖ Associate the characteristic with relay settings
- ❖ Select test point/ items directly on Z plain or in setting box
- ❖ Zone verification
- ❖ Z-T test
- ❖ Edit new characteristic

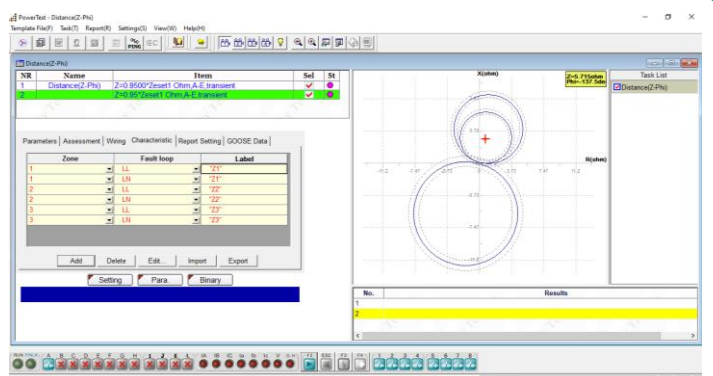

Directional

- ❖ Can search maximum torque angle and two boundary angles (Lead and lag angles)
- ❖ Can set angle define, V lead I or I lead V
- ❖ Can set fault type, single phase, phase-phase or three phase fault

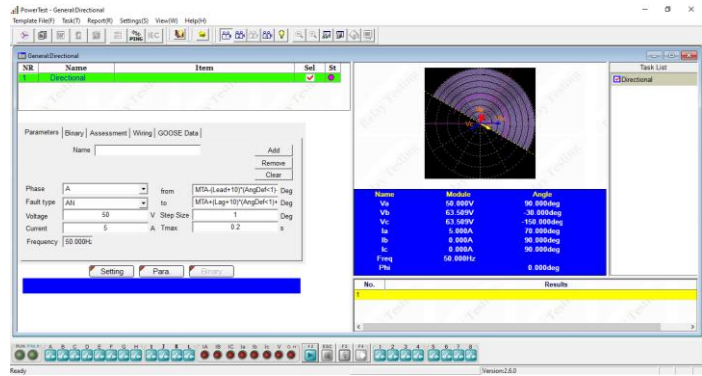

Auto-Reclosing

- ❖ Can test the reclose function
- ❖ Realize relay automatic reclosing with checking the difference between two systems, checking the synchronization setting, reclose set time checking and automatic evaluating of testing results.

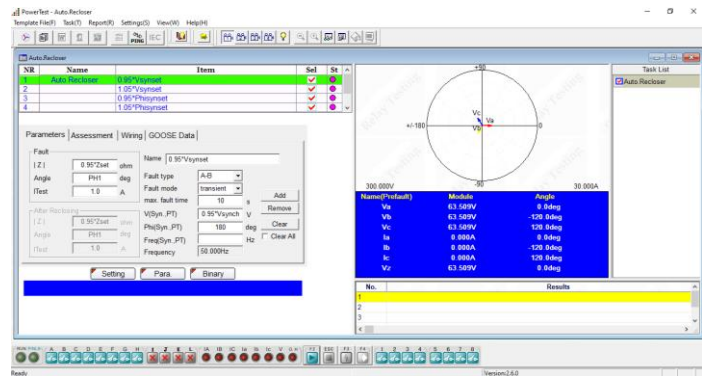

Differential (3I)

- ❖ Can search out the percentage restraint curve, harmonic restraint, trip time for single phase fault
- ❖ Can search the percentage restraint curve
- ❖ Can check 2nd harmonic restraint
- ❖ Can check 3rd harmonic restraint
- ❖ Can check 5th harmonic restraint
- ❖ Can check tripping time of set points

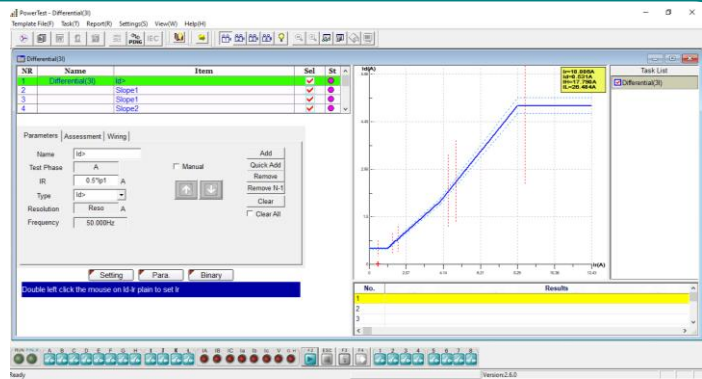

Differential (6I)

- ❖ Suitable for 6 output current channels' relay tester, such as transformer, generator and bus bar etc. differential protection equipment test
- ❖ Realize the two sides 3 phase/phase-phase/single phase test between relay tester and relay equipment.
- ❖ Can search the percentage restraint curve, harmonic restraint, trip time
- ❖ This module can be used by POM2-6143 only

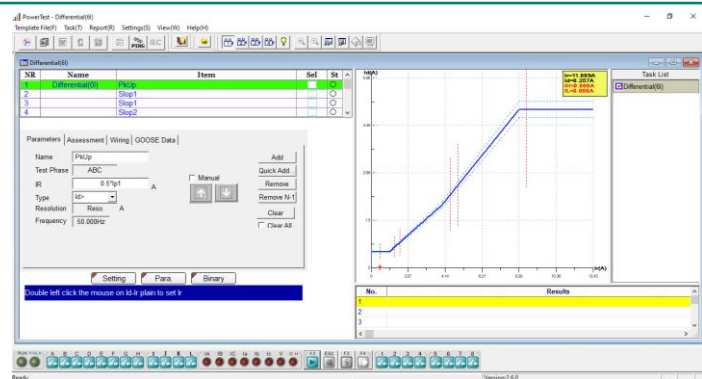

Time Inversed Current

- ❖ Realize the directional over-current test and non-directional over-current test
- ❖ Include testing positive sequence, negative sequence and zero sequence inverse-time over-current, definite-time over-current, over-heat protection.
- ❖ Can import the IEC and IEEE standard curve or user defined curve

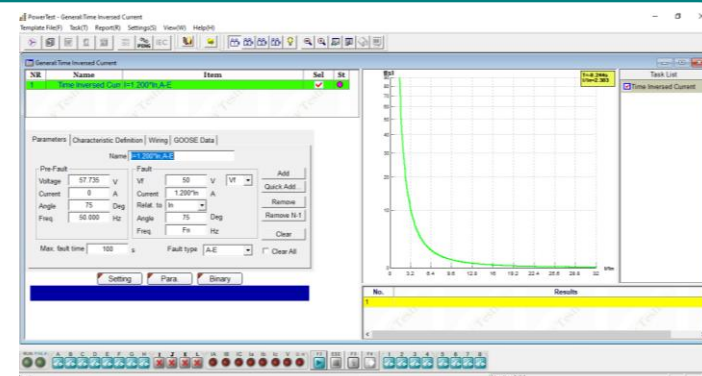

Time Inversed Voltage

- ❖ Can test time inversed over voltage and time inverse under voltage relay
- ❖ Include testing directional, time definite and with time delay voltage relay
- ❖ Can simulate three phase, phase-earth fault, and phase-phase fault

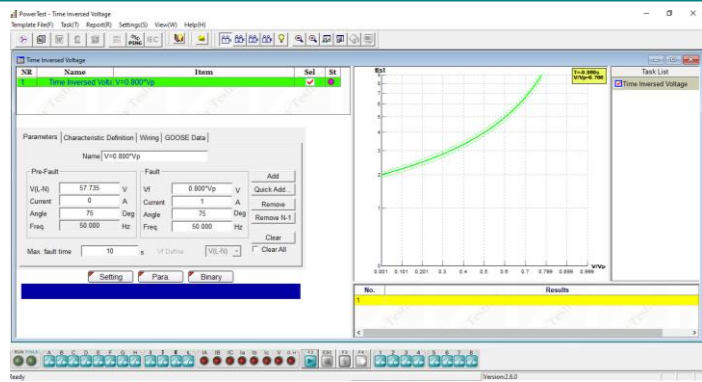

Frequency Relay

- ❖ Can test frequency protection relay, such as over frequency, under frequency, df/dt trip, df/dt blocking
- ❖ Including pick up frequency, trip time, df/dt setting value, voltage blocking value and current blocking value test

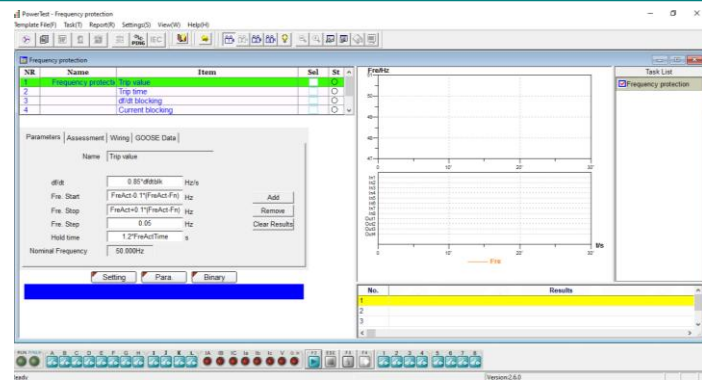

Voltage Relay

- ❖ Can test voltage protection relay including under voltage and over voltage
- ❖ Can test pick up voltage, trip time and dv/dt setting value

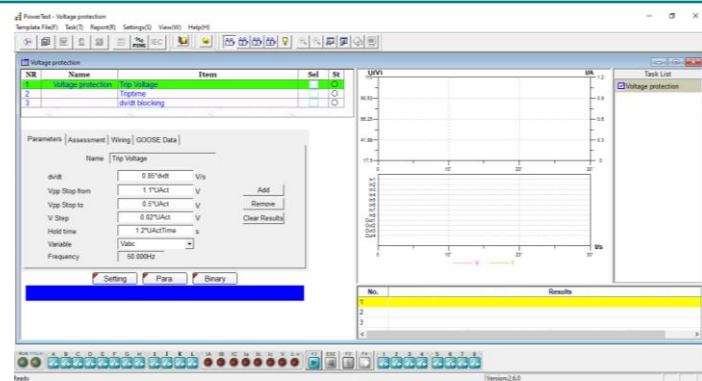

U. I. T Relay (AC)

- ❖ Can test AC type auxiliary/intermediate relay and AC type time relay
- ❖ Can test AC voltage type electromagnetic relay
- ❖ Can test AC current type electromagnetic relay
- ❖ Can test electromagnetic time relay picked-up by AC voltage
- ❖ Can test electromagnetic time relay picked-up by AC current

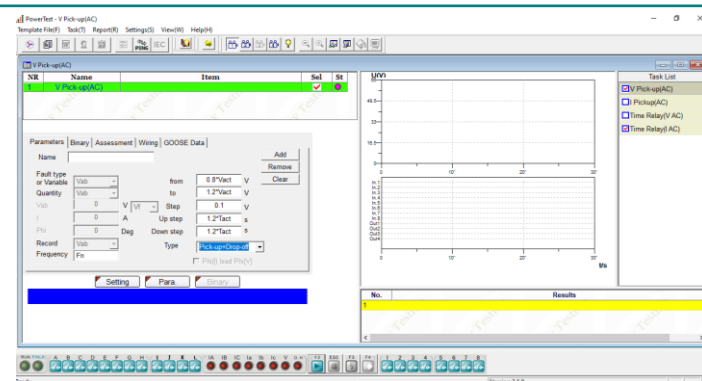

U. I. T Relay (DC)

- ❖ Can test DC type voltage relay. Auxiliary DC source Vdc is used for this test. Also DC current can be generated for some relays when it is required.
- ❖ Can test DC type current relay. Current source is used for this test. DC voltage can be generated for some relays when it is required.

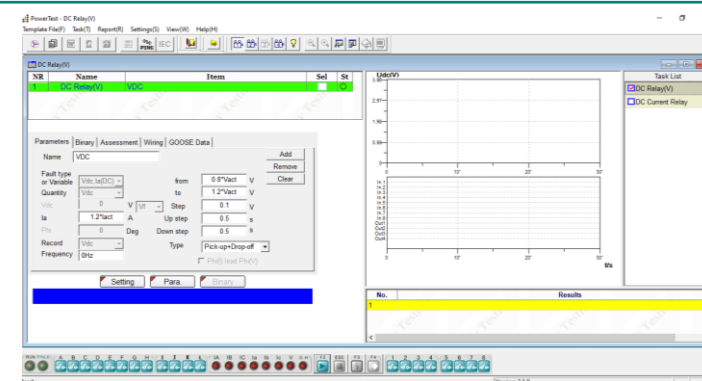

➤ Advanced Package

In the advanced package, the centralization testing the RX Characteristic Sweep, testing for distance relay, Advanced Differential, Advanced Transplay, Synchronization, etc.



Advanced Differential (3I)

- ❖ Can search the percentage restraint curve, harmonic restraint, trip time for single phase fault
- ❖ Can automatic to calculate the matching factor via the transformer parameter and CT/PT parameter
- ❖ Only check single phase fault

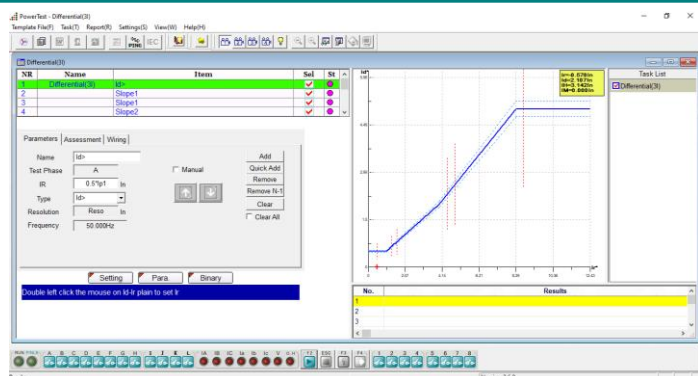

Advanced Differential (6I)

- ❖ Can search the percentage restraint curve, harmonic restraint, trip time
- ❖ Can automatic to calculate the matching factor via the transformer parameter and CT/PT parameter
- ❖ Can test single phase, phase-phase, three-phase fault
- ❖ This module can be used by POM2-6143 only

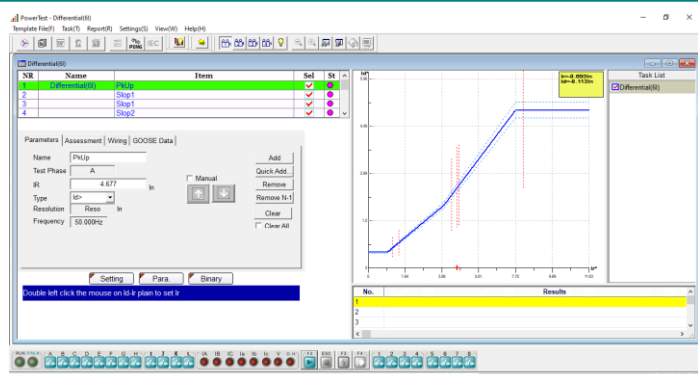

Advanced TransPlay(4V,3I)

- ❖ Can play back the COMTRADE format file, including CFG, which describe signal names, sampling frequencies, etc. and DAT which contains the sampling values for each channel.
- ❖ Can edit the COMTRADE data

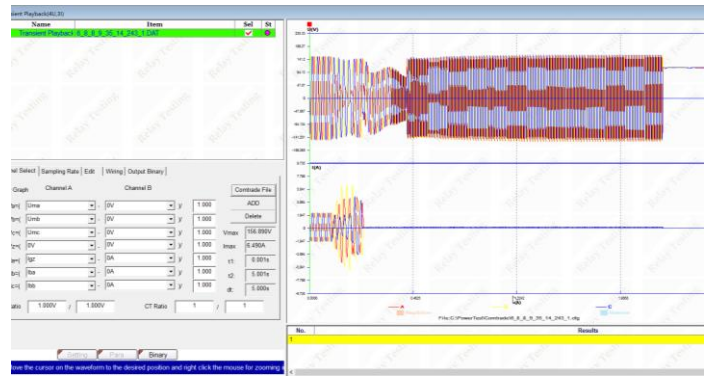

RX Characteristic Sweep

- ❖ Can search the characteristic boundary of the impedance relay
- ❖ Can find the boundary at different angles

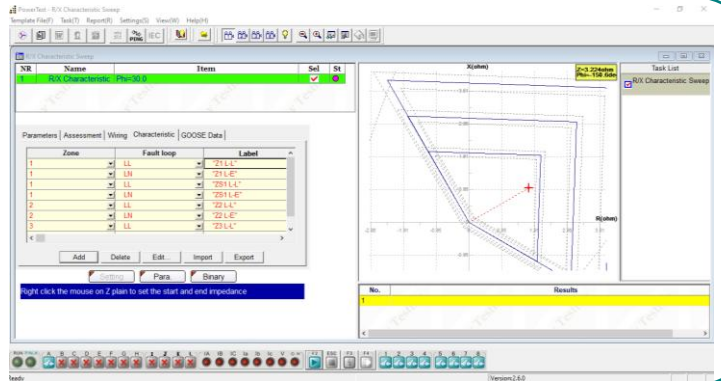

Synchronizer

- ❖ Can check synchronizing relay
- ❖ Can check voltage difference
- ❖ Can check frequency difference
- ❖ Can check leading time and leading angle
- ❖ Can check pulse width for frequency adjustment
- ❖ Can check pulse width for voltage adjustment
- ❖ Can check auto-adjusting function with both voltage and frequency varying

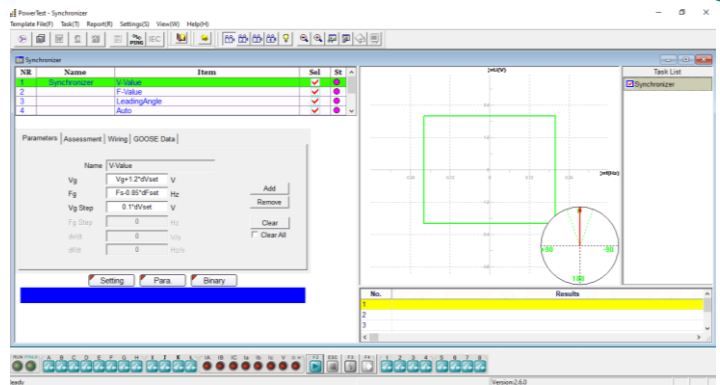

➤ Special Package

In the special package, there are energy meter module, power swing simulation module and Transducer module can be used by POM2.



Energy Meter

- ❖ Can check the functionality and accuracy of energy meter with or without optional accessory PACB108
- ❖ 1-phase or 3-phase energy meters can be checked
- ❖ Active power meter, reactive power meter, and apparent power meter can be checked

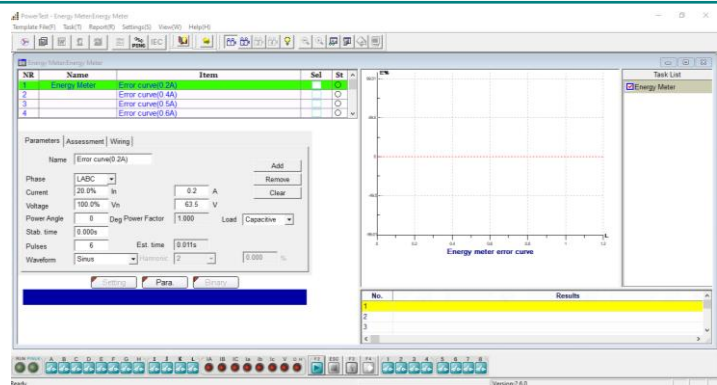

Power Swing Simulation

- ❖ Can really simulate the oscillations in power flow reference the power parameter
- ❖ Can simulate Out-of-Step and Stable swing
- ❖ Can simulate increase and decrease swing
- ❖ Can be a tool for relay test engineer to observe the relay behavior during dynamic power swing process.

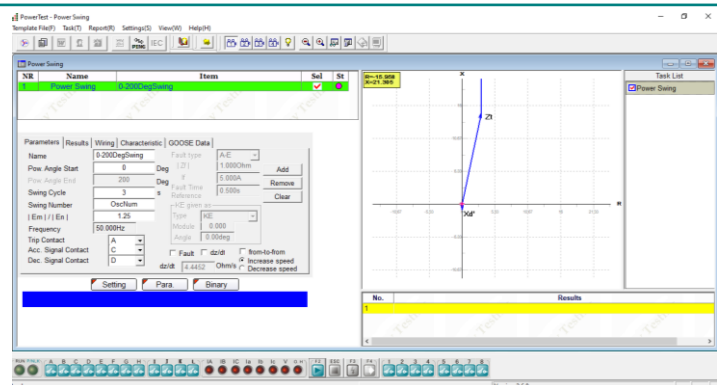

Transducer

- ❖ Can check accuracy of transducer

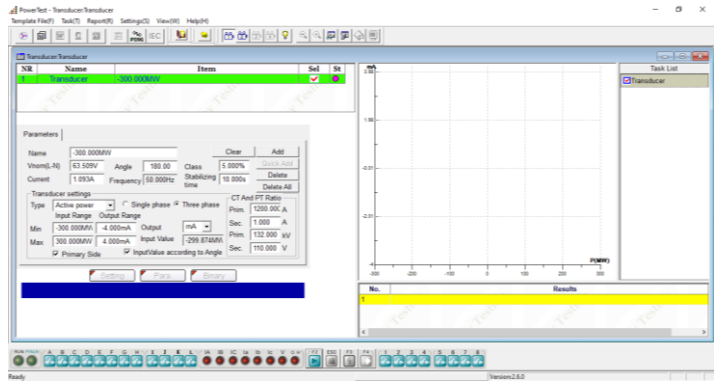
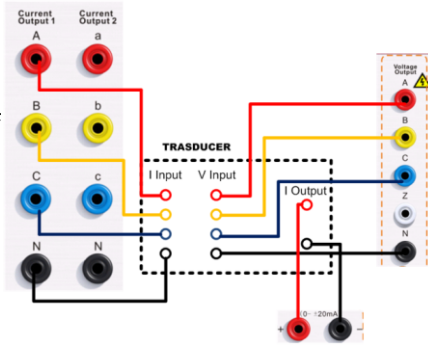

➤ New Modules Package

In the New Modules package, there are modules loss of excitation, QuickTest(harmonic), Transplay(6V, 6I) and QuickTest(Low Level) applied for POM2 series.



Loss of excitation

- ❖ Can search for two different excitation loss characteristics
- ❖ During the test process a series of shots will be generated to search out the boundary along this shot line. Then next shot at a different angle will be generated. In this way we can then find out the boundary at different angles.

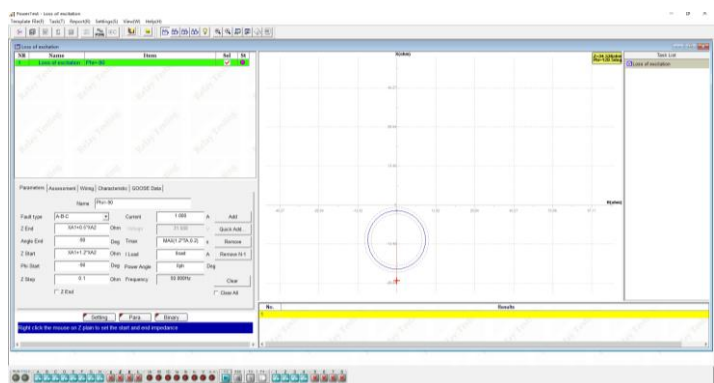

QuickTest (Harmonic)

- ❖ Can automatically and manually superposition harmonics with user-defined frequency
- ❖ The fundamental and harmonic of voltage and current sources can be controlled independently

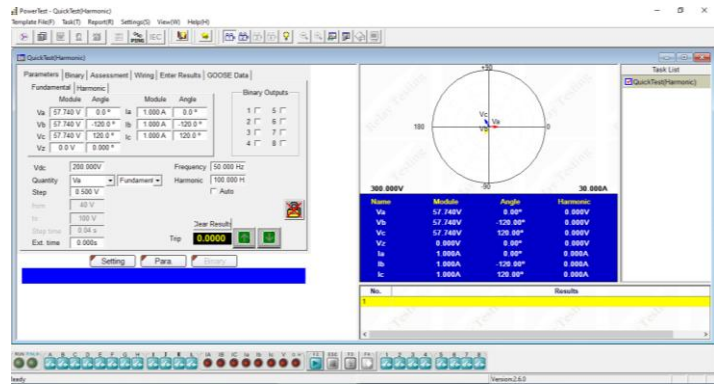

Transplay (6V, 6I)

- ❖ Can play back the COMTRADE format file which records 4 voltage channels and 6 current channels
- ❖ Display the waveform and data of the imported COMTRADE file
- ❖ This module can be used by POM2-6143 only

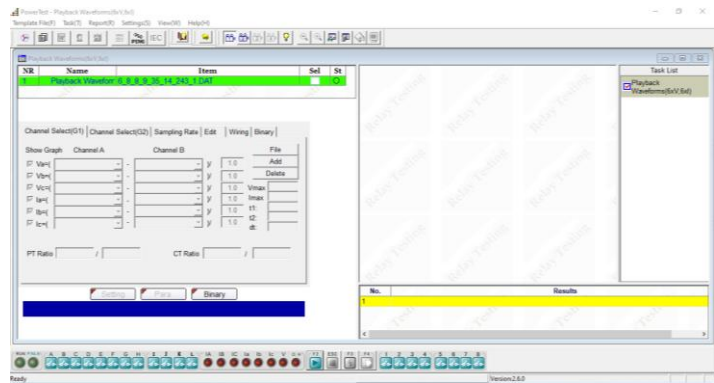

QuickTest (Low Level) (Optional)

- ❖ 12 low level voltage sources available for test purpose

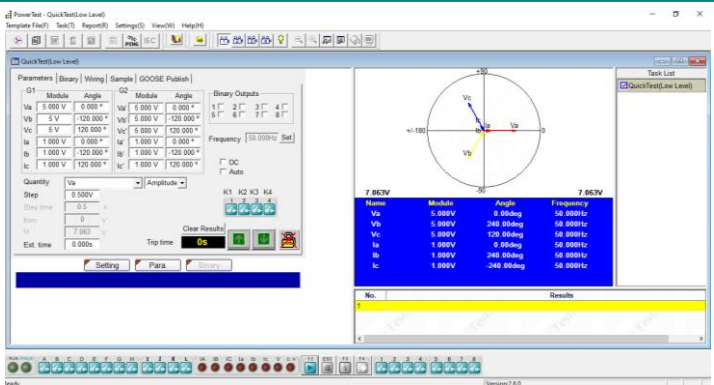

PONOVO Activities in Worldwide





PONOVO Template Service

Besides the above standard test modules, the relay templates are provided for the automatic testing purposes. Every relay template is created based on each relay model and its function from different relay manufacturers, and the setting names in the templates are the same as what they are in the relay, so it is easy for the engineer to conduct the site testing and simplify the works greatly. There are more than 500 different relay templates available for customers to download from the website for free.

The CSV/RIO/XIRO files can be imported into the templates by PowerTest.

The optional service such as offering the customized templates and reports is provided by PONOVO.

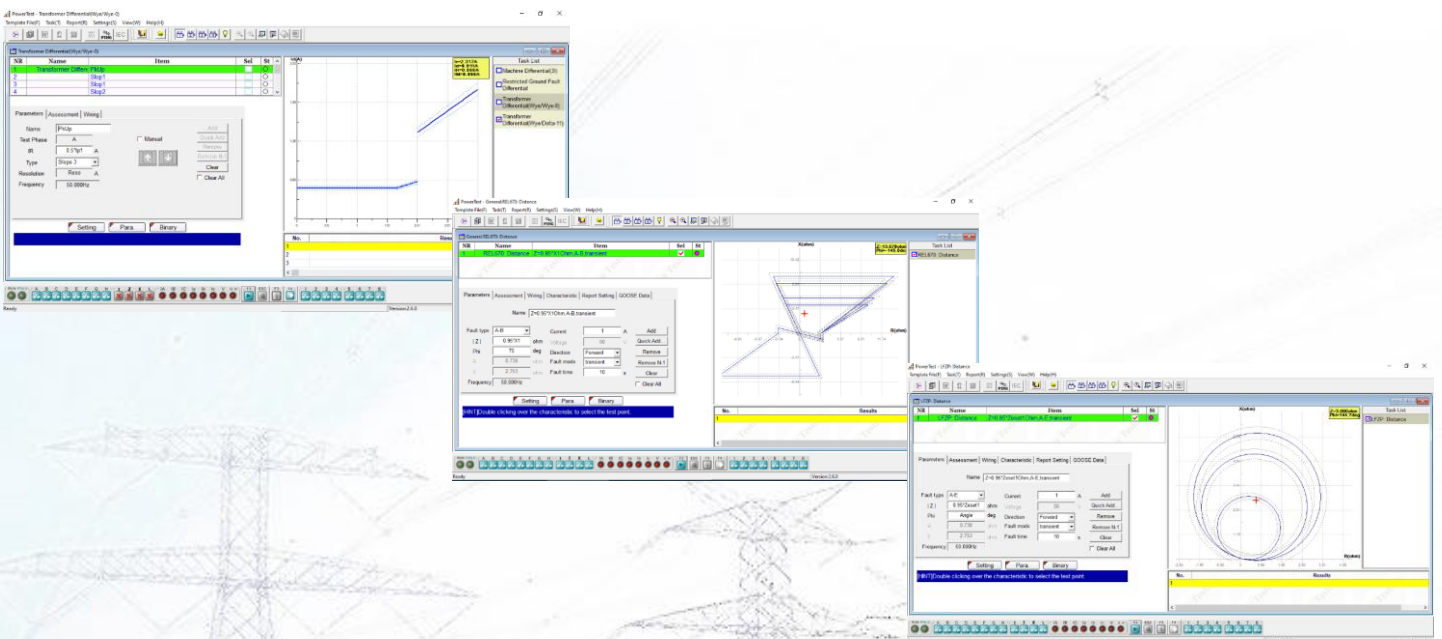
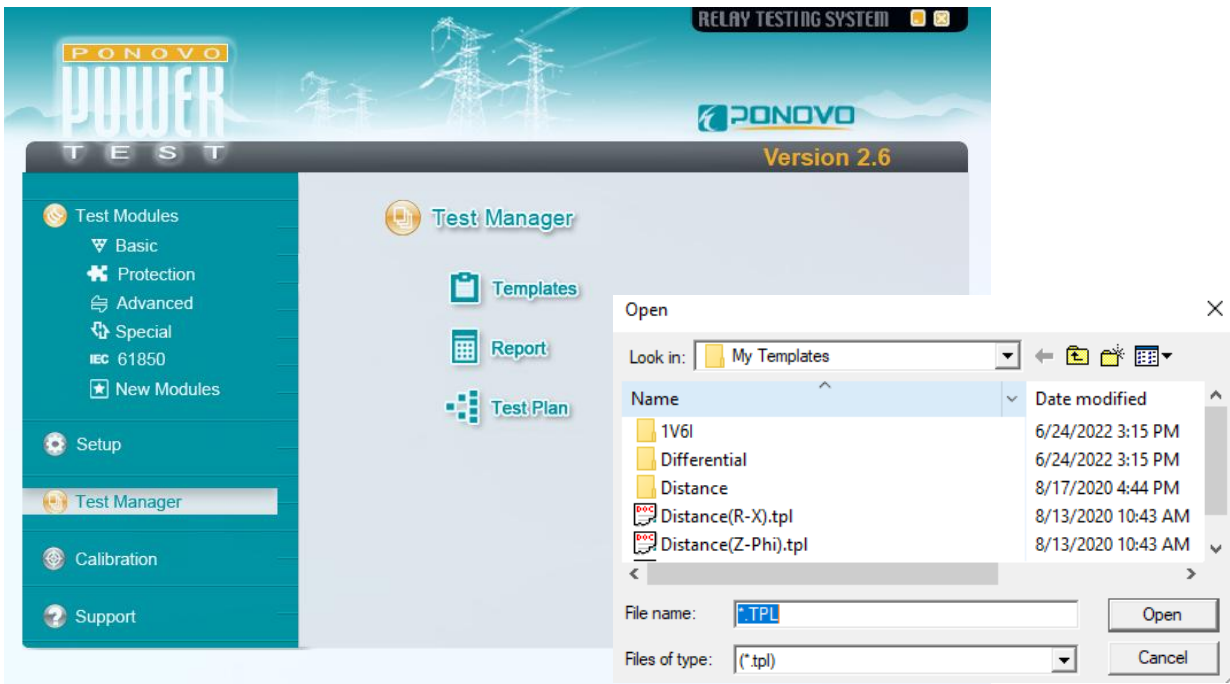

More Templates can be download from our website www.ponovo.net



- | | | | | | | | |
|---------|------------|--------|--------|--------|--------|-------------|----------|
| • CAG17 | • CTU | • P115 | • P142 | • P343 | • P438 | • P941 | • VAGM22 |
| • CTIG | • DIFB | • P120 | • P143 | • P344 | • P441 | • P942 | • VAPM |
| • CTIGM | • MFVUM | • P121 | • P144 | • P345 | • P442 | • P943 | • P632 |
| • CTMFM | • Micromho | • P122 | • P145 | • P430 | • P443 | • PPX | • P633 |
| • CTMM | • MVAPM | • P123 | • P241 | • P433 | • P921 | • PVMM | • P634 |
| • CTNM | • MWTU | • P124 | • P242 | • P435 | • P922 | • Quadromho | • P642 |
| • CTT | • Optimho | • P127 | • P243 | • P436 | • P923 | • SKE | • P643 |
| • CTTM | • P111 | • P141 | • P342 | • P437 | • P940 | • SKD | • P645 |



- | | | | | | | | | |
|-----------|-----------|----------|---------|----------|----------|----------|----------|----------|
| • SEL300 | • SEL411 | • 7RW600 | • 7SD5 | • 7ST6 | • LZ96 | • REC670 | • REL356 | • REL670 |
| • SEL351 | • SEL311C | • 7SA6XX | • 7SD52 | • 7UM61 | • REG100 | • REF542 | • REL511 | |
| • SEL587 | • SEL311L | • 7SA511 | • 7SD63 | • 7UM62 | • REL511 | • REG216 | • REL512 | |
| • SEL311B | • SEL321 | • 7SA513 | • 7SJ61 | • 7UM512 | • REL531 | • REL300 | • REL521 | |
| • SEL487B | • SEL421 | • 7SA518 | • 7SJ63 | • 7UM515 | • MSOC | • REL316 | • REL531 | |
| • SEL487E | • SEL501 | • 7SA519 | • 7SJ80 | | • RAZFE | • REL350 | • REL561 | |
| • SEL167 | • SEL587 | • 7SA522 | • 7SS52 | | • REB670 | • REL352 | • REL650 | |



- | | | | | | |
|-----------|-------------|---------|---------|--------------|---------|
| • PCS-902 | • PCS-9611 | • SR489 | • D60 | • SEPAM 10 | • MRA4 |
| • RCS-915 | • PCS-902H | • SR745 | • DLPD | • SEPAM 80 | • MRDT4 |
| • RCS-931 | • PCS-931D | • F650 | • G30 | • SEPAM 2000 | • MRI4 |
| • RCS-993 | • PCS-9611C | • SR750 | • L90 | • SEPAM S42 | • MRM |
| • RCS-902 | | • GT60 | • GE345 | • T20 | • MRN |



- GRB100
- GRD110
- GRD140
- GRD150
- GRF100
- GRL100

- F_PRO
- L_PRO
- T_PRO

- VAMP 255
- VAMP 265

- 326GD

- PCT210





Optional Accessories

• PW-VP50 CT Polarity checker



2 units. Master machine injects pulse current to primary side of CT, slave machine receives and analysis the waveform of induced pulse current at the secondary side so as to judge the polarity is positive or negative automatically by the LED indicator on the kits.

• GPS synchronization (PGPS02/PGPS04i)



PGPS02: It provides GPS synchronization signal in PPS (pulse per second) or PPM (pulse per minute) for synchronized test. Trigger time can be set for end- to-end test application.



PGPS04i: The PGPS04i is a multi-functional time synchronization device that integrates with GPS time synchronization, IRIG-B (DC-TTL/DC-RS422/optical) outputs, IRIG-B (DC-TTL/DC-RS422/fiber) pulse input, 1PPS/1PPM (DC-TTL/DC-RS232 /fiber) pulse output, timing set of whole trigger points, real-time clock auto-generating and other relevant functions.

• Circuit breaker simulator (PSS01)

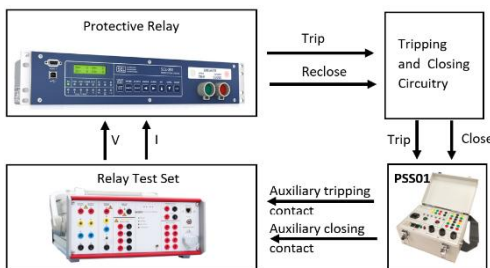

Working together with PONOVO relay testing device, PSS01 is to be used to simulate the circuit breaker operation for checking the relay scheme performance. Complicated software settings can be avoided by using this simple accessory.

• Scanning Head (PACB108)



The passive optical scanning head PACB108 detects the status of an LED, that is either an optical pulse output from an energy meter or the binary status of a protective relay or other similar optical source.



POM2-6143

Protective Relay Test Set



Specifications

Voltage generators

Setting range

4-phase ac(L-N) 4×0~300V

1-phase ac(L-L) 1×0~600V

dc (L-N) 4×±0~300V

dc (L-L) 1×±0~600V

Power

4-phase ac(L-N) 4×75VA typ., at 300V;
4×50VA guar., at 300V

3-phase ac(L-N) 3×100VA typ., at 300V;
3×85VA guar., at 300V

1-phase ac(L-L) 1× 200VA typ., at 600V;
1× 170VA guar., at 600V

dc (L-N) 4×100W at 300 V

Accuracy error < 0.08 % rd.+0.02 % rg. guar.,
at 0~300 V
< 0.02 % rd.+0.01 % rg. typ.,
at 0~300 V

Ranges 300V

Resolution 10mV

Distortion < 0.05 % typ., (< 0.1 % guar.)

Current generators

Setting range

6-phase ac(L-N) 6×0~15A

3-phase ac(2L-N) 3×0~30A

1-phase ac(3L-3L) 1×0~30A (10A/phase)

1-phase ac(6L-N) 1×0~90A

dc (L-N) 6×±0~10A

dc (6L-N) 1×±0~60A

Power

6-phase ac(L-N) 6×105VA at 15A

3-phase ac(2L-N) 3×210VA at 30A

1-phase ac(3L-3L) 1×420VA at 30A

dc(L-N) 6×100W at 10A

dc(6L-N) 600W at 60A

Max compliance voltage(L-N)(L-L)
10Vpk/20Vpk

Accuracy error < 0.08 % rd.+0.02 % rg. guar.,
at 0~15A
< 0.02 % rd.+0.01 % rg. typ.,
at 0~15A

Ranges 15A or 30A

Resolution 1mA

Distortion < 0.05 % typ.,
(< 0.1 % guar.)

General

Frequency

Sine signal DC, 0.001Hz~1000Hz

Transient signal DC ~10.0kHz

Accuracy ±0.3ppm

Resolution 0.001Hz

Phase

Angle range -360°~+360°

Accuracy <0.05° typ., <0.1° guar.
at 50/60Hz

Resolution ±0.001°

Binary inputs

Number	8
Input characteristics	0~400Vdc/ac (peak) with adjustable threshold or potential free
Time resolution	50μs
Max. measuring time	Infinite
Debounce/Deglitch time	0~25ms
Counting function	< 3kHz at pulse width>150μs

Binary outputs, relay

Number	4 (1-4)
Type	Potential free relay contacts, software controlled
Break capacity ac	Vmax: 300Vac /Imax: 8A /Pmax: 2000VA
Break capacity dc	Vmax: 300Vdc /Imax:8A /Pmax: 150W

Binary outputs, semiconductor

Number	4 (5-8)
Type	semiconductor
Break capacity	Vmax: 300Vdc /Imax:0.5A /Pmax: 150W
Update rate	100μs
Imax	0.5A

Auxiliary dc supply

Voltage range	0~300V
Power	88W at 110V, 110W at 220V, 100W at 300V
Accuracy	error < 0.1 % rg. typ. (<0.5 % rg. guar.)

DC voltage measuring inputs

Measuring range	0~±10V
Accuracy	error <0.02% rg. typ. (<0.05% rg. guar.)
Input impedance	100KΩ

DC current measuring inputs

Measuring range	0~±20mA
Accuracy	error<0.02% rg. typ. (<0.05% rg. guar.)
Input impedance	50Ω

Low level outputs

Setting range	12×0~10Vpk
Max. output current	1mA
Accuracy	error< 0.025 % typ. < 0.07 % guar. at 1~10Vpk
Resolution	250μV
Distortion(THD+N)	< 0.05 % typ. (< 0.1 % guar.)
Connection	14 pin combination socket

Power supply

Nominal input voltage	110~240Vac
Permissible input voltage	90~260Vac
Nominal frequency	50/60Hz
Permissible frequency	45~65Hz

Environmental conditions

Operation temperature	0~+50°C
Storage temperature	-25~+70°C
Relative humidity	5~95% non-condensing

EMC(E&I)	EN/IEC 61326-1
Safety	EN/IEC 61010-1/1-12/2-030 EN/IEC 60255-25/27
Others	FCC Part 15: Sub B ECS-001:2006 LVD EU ZEK 01.4 -08/11/11

Others

PC connection	Ethernet,10M/100M
Low level outputs interface (Optional)	Circular connector
GPS/IRIG-B interface	Circular connector
IEC61850 Goose	Ethernet interface (Optional)
Ground Socket(earth)	4mm banana socket
Weight	16kg
Dimensions (W x H x D)	390mm ×287mm×214mm



POM2-3243

Protective Relay Test Set



Specifications

Voltage generators

Setting range

4-phase ac(L-N) 4×0~300V

1-phase ac(L-L) 1×0~600V

dc (L-N) 4×±0~300V

dc (L-L) 1×±0~600V

Power

4-phase ac(L-N) 4×75VA typ., at 300V
4×50VA guar., at 300V

3-phase ac(L-N) 3×100VA typ., at 300V
3×85VA guar., at 300V

1-phase ac(L-L) 1× 200VA typ., at 600V
1× 170VA guar., at 600V

dc (L-N) 4×100W at ±300 V

Accuracy error < 0.08 % rd.+0.02 % rg. guar.,
at 0~300 V
< 0.02 % rd.+0.01 % rg. typ.,
at 0~300 V

Ranges 300V

Resolution 10mV

Distortion < 0.05 % typ., (< 0.1 % guar.)

Current generators

Setting range

3-phase ac(L-N) 3×0~20A

1-phase ac(3L-N) 1×0~60A

1-phase ac(L-L) 1×0~20A

dc (L-N) 3×±0~10A

dc (3L-N) 1×±0~30A

Power

3-phase ac(L-N) 3×140VA at 20A

1-phase ac(L-L) 1×280VA at 20A

1-phase ac(3L-N) 1×280VA at 60A

dc(L-N) 3×100W at 10A

dc(3L-N) 1×300W at 30A

Max compliance voltage(L-N)(L-L)
10Vpk/20Vpk

Accuracy error <0.08 % rd.+0.02 % rg. guar.,
<0.02 % rd.+0.01 % rg. typ.

Ranges 20A

Resolution 1mA

Distortion < 0.05 % typ.
< 0.1 % guar.

General

Frequency

Sine signal DC, 0.001Hz~1000Hz

Transient signal DC ~10.0kHz

Accuracy ±0.3ppm

Resolution 0.001Hz

Phase

Angle range -360°~+360°

Accuracy <0.05° typ.
<0.1° guar.
at 50/60Hz

Resolution ±0.001°

Binary inputs

Number	8
Input characteristics	0~400V dc/ac (peak) with adjustable threshold or potential free
Time resolution	50μs
Max. measuring time	Infinite
Debounce/Deglitch time	0~25ms
Counting function	< 3kHz at pulse width>150μs

Binary outputs, relay

Number	4 (1-4)
Type	Potential free relay contacts, software controlled
Break capacity ac	Vmax: 300Vac /Imax: 8A /Pmax: 2000VA
Break capacity dc	Vmax: 300Vdc /Imax:8A /Pmax: 150W

Binary outputs, semiconductor

Number	4 (5-8)
Type	semiconductor
Break capacity	Vmax: 300Vdc /Imax:0.5A /Pmax: 150W
Update rate	100μs
Imax	0.5A

Auxiliary dc supply

Voltage range	0~300V
Power	88W at 110V, 110W at 220V, 100W at 300V
Accuracy	error < 0.1 % rg. typ. (<0.5 % rg. guar.)

DC voltage measuring inputs (Optional)

Measuring range	0~±10V
Accuracy	error <0.02% rg. typ. (<0.05% rg. guar.)
Input impedance	100KΩ

DC current measuring inputs (Optional)

Measuring range	0~±20mA
Accuracy	error <0.02% rg. typ. <0.05% rg. guar.
Input impedance	50Ω

Low level outputs (Optional)

Setting range	12×0~10Vpk
Max. output current	1mA
Accuracy	error < 0.025 % typ. < 0.07 % guar.at 1~10Vpk
Resolution	250μV
Distortion(THD+N)	< 0.05 % typ. < 0.1 % guar.
Connection	14 pin combination socket

Power supply

Nominal input voltage	110~240Vac
Permissible input voltage	90~260Vac
Nominal frequency	50/60Hz
Permissible frequency	45~65Hz

Environmental conditions

Operation temperature	0~+50°C
Storage temperature	-25~+70°C
Relative humidity	5~95% non-condensing

EMC(E&I)	EN/IEC 61326-1
Safety	EN/IEC 61010-1/1-12/2-030 EN/IEC 60255-25/27
Others	FCC Part 15: Sub B ECS-001:2006 LVD EU ZEK 01.4 -08/11/11

Others

PC connection	Ethernet, 10M/100M
Low level outputs interface (Optional)	Circular connector
GPS/IRIG-B interface	Circular connector
IEC61850 Goose	Ethernet interface (Optional)
Ground Socket(earth)	4mm banana socket
Weight	13kg
Dimensions (W x H x D)	390mm ×287mm×194mm

Professional Solution Provider For The Power World

Since 2001, Ponovo Power has been focusing on providing professional solutions to over 5000 clients in the fields of intelligent testing and power quality control in China and abroad



PONOVO POWER CO., LTD.

No.139 Jinghai Third Road, BDA, Beijing, China. 100176

Tel : +86 (10) 59089666

Fax: +86 (10) 59089999

www.ponovo.net

info@relaytest.com